

SPARTUS®

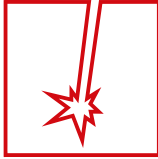

Professional
3D WELDING TABLES
D28 system



Ladies and gentlemen,

We have been introducing modern solutions in the welding industry for years. We focus on quality, durability and comfort of use. We value our clients' time and work. Thanks to the continuous development of the SPARTUS® brand, we have expanded our offer to professional welding tables. The tables are divided into three series, differing in the type of table surface so we can meet your expectations.









A wide selection of accessories will allow you to work with even the most demanding elements. The presented assortment will significantly streamline, speed up and optimize the welding process, even where special precision is required.

We hope that the quality and comfort of work with SPARTUS® welding tables will become an indispensable element of your everyday life.

WELDING TABLES

FERROS		4
HERMES		6
MAXIMUS		8
FERROS WITH ROTARY TABLES		10
FERROS WITH ROTARY POSITIONERS		11
LIFT WELDING TABLES		12

ACCESSORIES

SQUARE SHAPE		15
LOCKING ANGLES AND ANGLE BRACKETS		16
CLAMPING SLEEVES		19
PRISMS		20
STOPS		21
CLAMPING BRIDGES		22
CLAMPING BOLTS		23
TOGGLE CLAMPS		24
MAINTENANCE		27
ADDITIONAL ACCESSORIES		28
ACCESSORY KITS		30

FERROS



USE THE SPACE FOR MORE EFFECTIVE WORK
OFFERED BY FERROS TABLES!



CAST IRON TABLE TOPS

TABLE LEGS

BASIC LEG

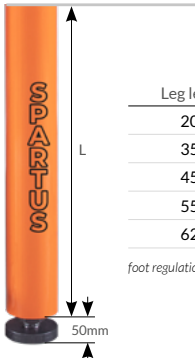

Leg length (L)	Table height
200mm	450mm
350mm	600mm
450mm	700mm
550mm	800mm
620mm	870mm

foot regulation max. +5cm

LEG WITH WHEEL

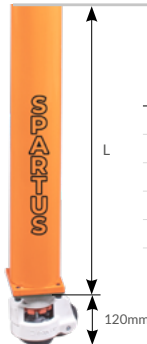

Leg length (L)	Table height
200mm	520mm
350mm	670mm
450mm	770mm
550mm	870mm
620mm	940mm

25mm TABLE TOP

The table top with a thickness of 25 mm guarantees the durability of the table and resistance to mechanical damage.

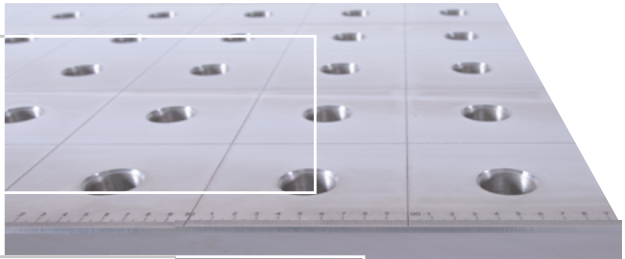

MILLIMETRIC SCALE

The applied millimeter scale facilitates precise assembly of the element to be processed.

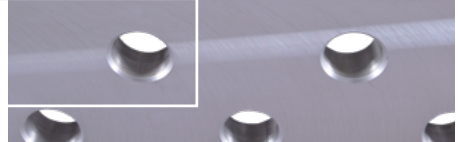

EN-GJL-300 CAST IRON

The casting of the top is made of EN-GJL-300 high strength cast iron characterized by high wear resistance.

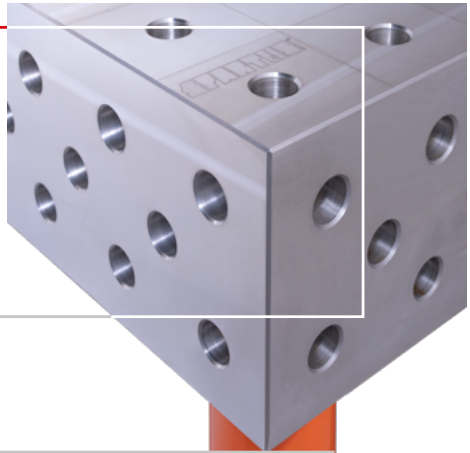

3D SIDE

It allows to expand the working surface and joining the table tops.

D28 SYSTEM

Drilled and chamfered holes 28mm.

FERROS WELDING TABLES WITH LEGS

Leg length (L) \ Size of the top	200mm	350mm	450mm	550mm	620mm
1200x1200x200mm	SP28C-12-12-200	SP28C-12-12-350	SP28C-12-12-450	SP28C-12-12-550	SP28C-12-12-620
1500x1000x200mm	SP28C-15-10-200	SP28C-15-10-350	SP28C-15-10-450	SP28C-15-10-550	SP28C-15-10-620
2000x1000x200mm	SP28C-20-10-200	SP28C-20-10-350	SP28C-20-10-450	SP28C-20-10-550	SP28C-20-10-620
2400x1200x200mm	SP28C-24-12-200	SP28C-24-12-350	SP28C-24-12-450	SP28C-24-12-550	SP28C-24-12-620
3000x1500x200mm	SP28C-30-15-200	SP28C-30-15-350	SP28C-30-15-450	SP28C-30-15-550	SP28C-30-15-620

Above, tables with basic legs. In the version with wheels, the letter M appears at the end of the product code.

Current prices
for FERROS tables...



HERMES



RELY ON COMFORT DURING WELDING,
BY USING THE HERMES TABLES!



WELDED STEEL TABLE TOPS

TABLE LEGS

BASIC LEG

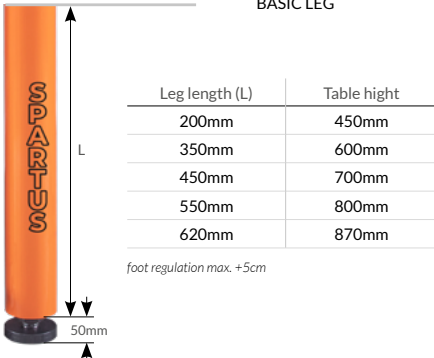

LEG WITH WHEEL

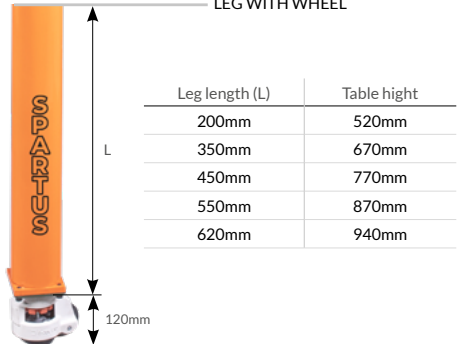

25mm TABLE TOP

The table top with a thickness of 25 mm guarantees the durability of the table and resistance to mechanical damage.

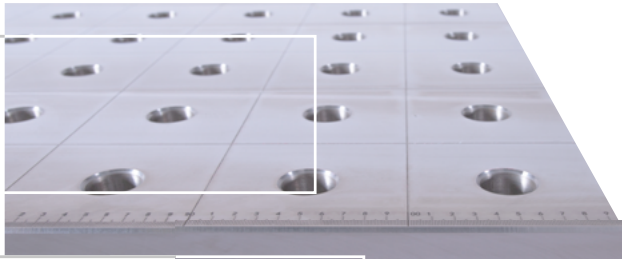

MILLIMETRIC SCALE

The applied millimeter scale facilitates precise assembly of the element to be processed.

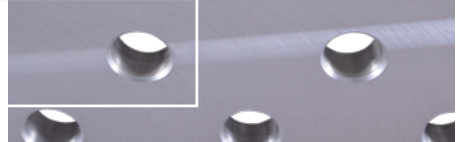

S355J2+N STEEL

Welding table top is made of S355J2+N steel grade, which is characterized by high strength and resistance to impact and deformation, and also provides protection against corrosion and weld spatter.

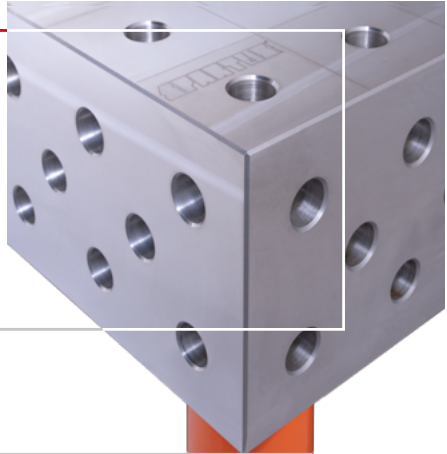

3D SIDE

It allows to expand the working surface and joining the table tops.

D28 SYSTEM

Drilled and chamfered holes 28mm.

HERMES WELDING TABLES WITH LEGS

Leg length (L) \ Size of the top	200mm	350mm	450mm	550mm	620mm
1200x1200x200mm	SP28W-12-12-200	SP28W-12-12-350	SP28W-12-12-450	SP28W-12-12-550	SP28W-12-12-620
1500x1000x200mm	SP28W-15-10-200	SP28W-15-10-350	SP28W-15-10-450	SP28W-15-10-550	SP28W-15-10-620
2000x1000x200mm	SP28W-20-10-200	SP28W-20-10-350	SP28W-20-10-450	SP28W-20-10-550	SP28W-20-10-620
2400x1200x200mm	SP28W-24-12-200	SP28W-24-12-350	SP28W-24-12-450	SP28W-24-12-550	SP28W-24-12-620
3000x1500x200mm	SP28W-30-15-200	SP28W-30-15-350	SP28W-30-15-450	SP28W-30-15-550	SP28W-30-15-620

Above, tables with basic legs. In the version with wheels, the letter M appears at the end of the product code.

Current prices
for HERMES tables...



MAXIMUS



GUARANTEE YOURSELF CONSTANT SUPPORT
WITH MAXIMUS TABLES!



PLASMA NITRIDED WELDED TABLE TOPS

TABLE LEGS

BASIC LEG

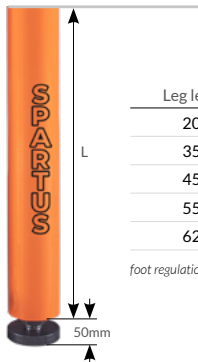

Leg length (L)	Table height
200mm	450mm
350mm	600mm
450mm	700mm
550mm	800mm
620mm	870mm

foot regulation max. +5cm

LEG WITH WHEEL

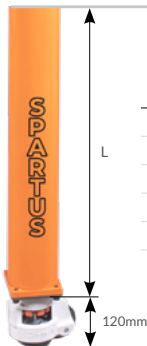

Leg length (L)	Table height
200mm	520mm
350mm	670mm
450mm	770mm
550mm	870mm
620mm	940mm

25mm TABLE TOP

The table top with a thickness of 25 mm guarantees the durability of the table and resistance to mechanical damage.

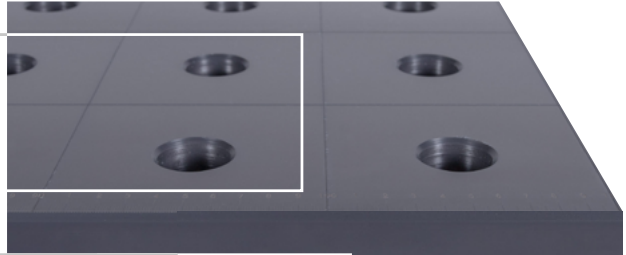

MILLIMETRIC SCALE

The applied millimeter scale facilitates precise assembly of the element to be processed.



S355J2+N NITREDED STEEL

S355J2+N steel grade used to make the welding table gives high strength, impact and scratch resistance, whereas plasma nitrided welded top significantly enhances protection against corrosion and weld spatter.

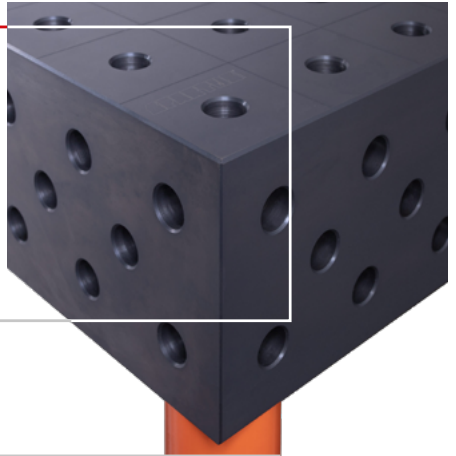

3D SIDE

It allows to expand the working surface and joining the table tops.

D28 SYSTEM

Drilled and chamfered holes 28mm.

MAXIMUS WELDING TABLES WITH LEGS

Leg length (L) \ Size of the top	200mm	350mm	450mm	550mm	620mm
1500x1000x200mm	SP28N-15-10-200	SP28N-15-10-350	SP28N-15-10-450	SP28N-15-10-550	SP28N-15-10-620
2000x1000x200mm	SP28N-20-10-200	SP28N-20-10-350	SP28N-20-10-450	SP28N-20-10-550	SP28N-20-10-620
2400x1200x200mm	SP28N-24-12-200	SP28N-24-12-350	SP28N-24-12-450	SP28N-24-12-550	SP28N-24-12-620
3000x1500x200mm	SP28N-30-15-200	SP28N-30-15-350	SP28N-30-15-450	SP28N-30-15-550	SP28N-30-15-620

Above, tables with basic legs. In the version with wheels, the letter M appears at the end of the product code.

Current prices
for MAXIMUS tables...





INCREASE YOUR EFFICIENCY THANKS TO MODERN SOLUTIONS!

FERROS WITH ROTARY TABLE

ROTATING TABLE TOP 25mm

The table top with a thickness of 25 mm guarantees the durability of the table and resistance to mechanical damage. The table allows the table top to be rotated in both directions by 360°.

EN-GJL-300 CAST IRON

The casting of the top is made of EN-GJL-300 high strength cast iron characterized by high wear resistance.

D28 SYSTEM

Drilled and chamfered holes 28mm.

INTUITIVE CONTROL

The foot switch and the manual control panel allow for easy and comfortable work with a rotary table.

SMOOTH-RUNNING

Adjustable start with gentle braking ensures smooth rotation during operation.



TABLE TOP DIMENSIONS	PRODUCT CODE	ROTARY TABLE	TABLE LOAD CAPACITY
1200x1200x200mm	SP28C-12-12-RT1000	SPARTUS® 1000	1000kg
	SP28C-12-12-RT2000	SPARTUS® 2000	2000kg
	SP28C-12-12-RT3000	SPARTUS® 3000	3000kg
	SP28C-12-12-RT5000	SPARTUS® 5000	5000kg
1400x1400x200mm	SP28C-14-14-RT1000	SPARTUS® 1000	1000kg
	SP28C-14-14-RT2000	SPARTUS® 2000	2000kg
	SP28C-14-14-RT3000	SPARTUS® 3000	3000kg
	SP28C-14-14-RT5000	SPARTUS® 5000	5000kg

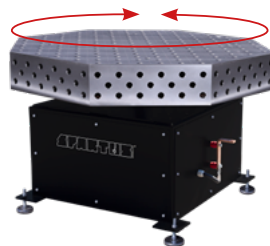

FERROS WITH ROTARY POSITIONER

ROTATING TABLE TOP 25mm

The table top with a thickness of 25 mm guarantees the durability of the table and resistance to mechanical damage. The table allows the table top to be rotated in both directions by 360°.

EN-GJL-300 CAST IRON

The casting of the top is made of EN-GJL-300 high strength cast iron characterized by high wear resistance.

CHANGING THE TILT ANGLE

The positioner mechanism allows the table top to be tilted up to 90°.

SMOOTH-RUNNING

Adjustable start with gentle braking ensures smooth rotation during operation.

D28 SYSTEM

Drilled and chamfered holes 28mm.



Product presentation

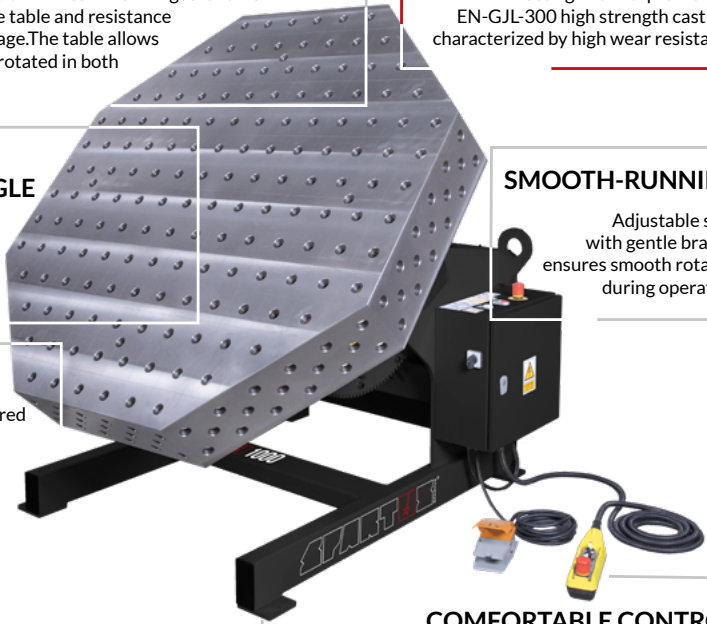

COMFORTABLE CONTROL

The foot switch and the manual control panel allow for easy and comfortable work with a rotary positioner.

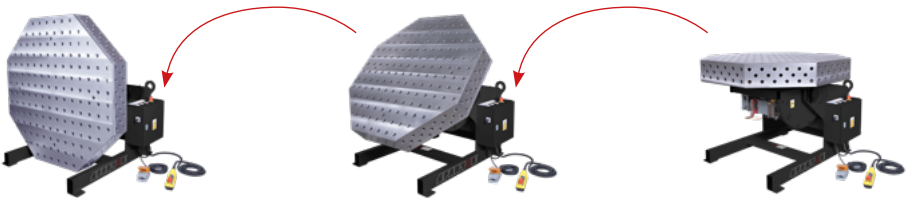

TABLE TOP DIMENSIONS	PRODUCT CODE	POSITIONER	POSITIONER LOAD CAPACITY
1200x1200x200mm	SP28C-12-12-RP1000	SPARTUS® 1000	1000kg
	SP28C-12-12-RP2000	SPARTUS® 2000	2000kg
	SP28C-12-12-RP5000	SPARTUS® 5000	5000kg
1400x1400x200mm	SP28C-14-14-RP1000	SPARTUS® 1000	1000kg
	SP28C-14-14-RP2000	SPARTUS® 2000	2000kg
	SP28C-14-14-RP5000	SPARTUS® 5000	5000kg





SPARTUS® LIFT WELDING TABLES

HEIGHT PRECISE ADJUSTMENT

Setting the table top at the right customised height enhances the level of comfort during the performance of lengthy tasks, which has a significant impact on the work efficiency and welding quality.

LIFT CAPACITY

Lifting system with a high capacity allows you to load the unit with large-size elements and apply accessories to facilitate element assembly.

MOBILITY

For a table top 2000x1000x200mm the lift system uses wheels, including two with a braking system, supporting safe and trouble-free movement of the welding table.

REMOTE CONTROL



SAFETY

The mobile lift is equipped with two protections:

MAINTENANCE INTERLOCKING SYSTEM



LIMIT SWITCH *crushing protection*

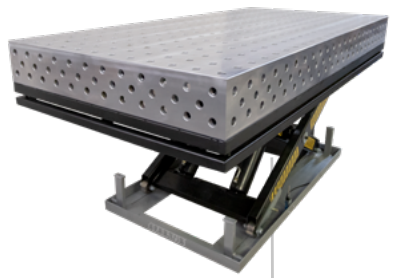

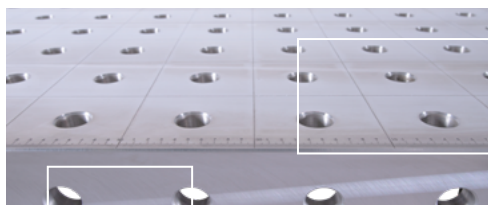

D28 SYSTEM

Drilled and chamfered holes 28mm.

25mm TABLE TOP

The table top with a thickness of 25 mm guarantees the durability of the table and resistance to mechanical damage.

MILLIMETRIC SCALE

The applied millimeter scale facilitates precise assembly of the element to be processed.

3D SIDE

It allows to expand the working surface and joining the table tops.



**LIFT AVAILABLE ON SPARTUS® TABLES in electrohydraulic version
WITH TABLETOPS DIMENSIONS: 2000 x 1000mm and 2400 x 1200mm**

FERROS

EN-GJL-300 CAST IRON

The casting of the top is made of EN-GJL-300 high strength cast iron characterized by high wear resistance.

TABLETOPS DIMENSIONS	PRODUCT CODE	LOAD CAPACITY	HEIGHT ADJUSTMENT
2000X1000X200	SP28C-20-10-PE	2200kg	530-1000mm
2400X1200X200	SP28C-24-12-PE	3000kg	525-1325mm

HERMES

S355J2+N STEEL

Welding table top is made of S355J2+N steel grade, which is characterized by high strength and resistance to impact and deformation, and also provides protection against corrosion and weld spatter.

TABLETOPS DIMENSIONS	PRODUCT CODE	LOAD CAPACITY	HEIGHT ADJUSTMENT
2000X1000X200	SP28W-20-10-PE	2200kg	530-1000mm
2400X1200X200	SP28W-24-12-PE	3000kg	525-1325mm

MAXIMUS

S355J2+N NITREDED STEEL

S355J2+N steel grade used to make the welding table gives high strength, impact and scratch resistance, whereas plasma nitrided welded top significantly enhances protection against corrosion and weld spatter.

TABLETOPS DIMENSIONS	PRODUCT CODE	LOAD CAPACITY	HEIGHT ADJUSTMENT
2000X1000X200	SP28N-20-10-PE	2200kg	530-1000mm
2400X1200X200	SP28N-24-12-PE	3000kg	525-1325mm

ACCESSORIES



Our offer includes a wide range of accessories to meet your individual needs. Accessories are available both as individual elements and ready-made sets.



SQUARE SHAPE

are perfect as an extension or widening of the table. At the same time they are the basis for vertical constructions and many combinations with other accessories.

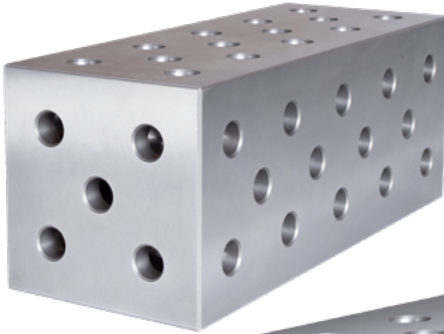
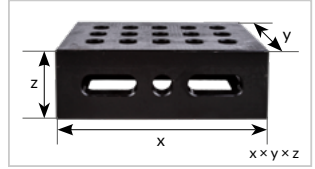

SP010-20-050
500mm × 200mm × 200mm

SP010-20-100

1000mm × 200mm × 200mm

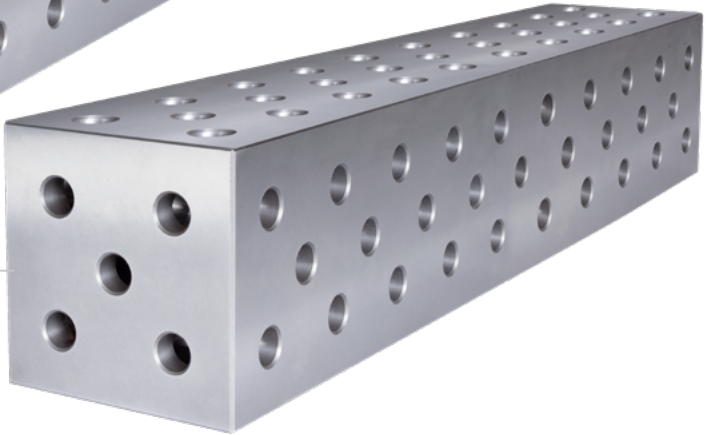

SP010-21-100
1000mm × 200mm × 100mm



SP010-22-030
300mm × 200mm × 100mm

SP010-22-050
500mm × 200mm × 100mm



LOCKING ANGLES AND ANGLE BRACKETS

are used to fix moving parts during heavy duty operations and they can also be an extension of the welding table. Available in right and left hand versions.

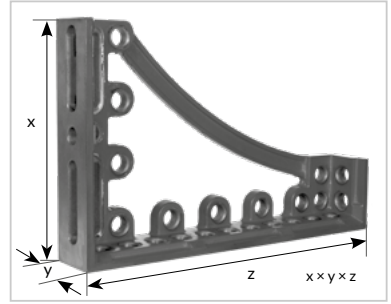

SP010-23-300L

275mm × 100mm × 300mm

SP010-23-300R

275mm × 100mm × 300mm

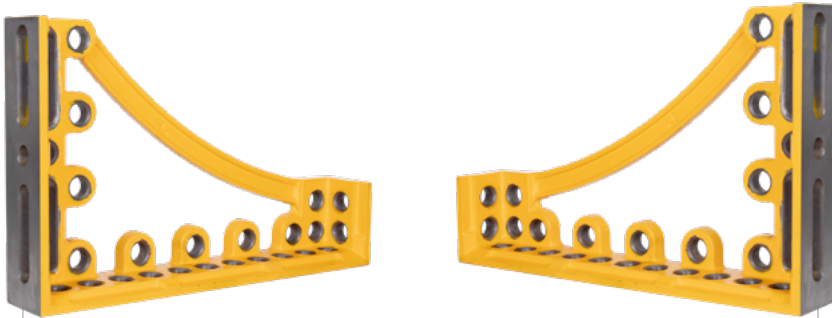

SP010-23-600L

375mm × 100mm × 600mm

SP010-23-600R

375mm × 100mm × 600mm

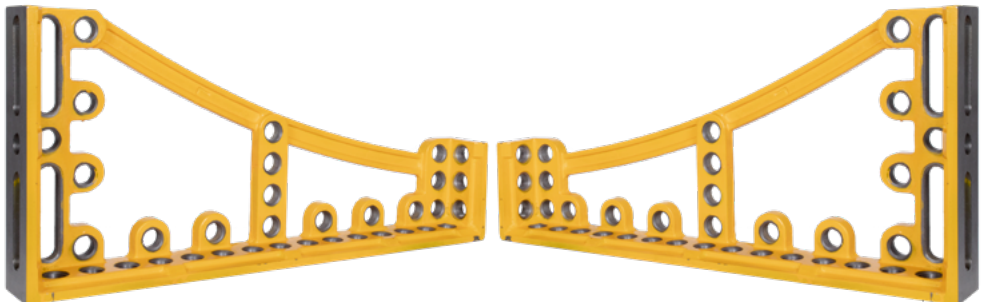

SP010-23-800L

375mm × 100mm × 800mm

SP010-23-800R

375mm × 100mm × 800mm

LOCKING ANGLES AND ANGLE BRACKETS

The use of a combination of holes and slots allows you to build work structures freely. When connecting large components, they are used as an angle block.

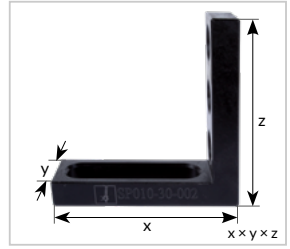

SP010-30-002
175mm × 50mm × 175mm



SP010-30-005
175mm × 50mm × 75mm



SP010-30-003
175mm × 50mm × 175mm



SP010-30-004
175mm × 50mm × 175mm



SP010-30-013
175mm × 50mm × 275mm

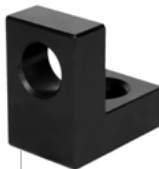

SP010-30-006
75mm × 50mm × 75mm

FLAT SQUARES

The longitudinal slot and the system slots offer an option of permanently clamping, adjusting, positioning and locking the assembly elements.

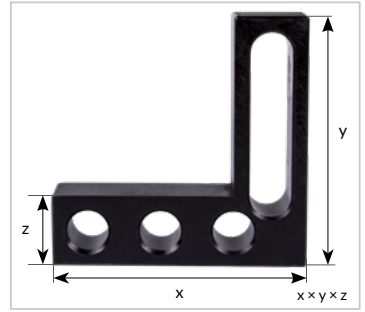

SP010-31-001
225mm × 325mm × 25mm

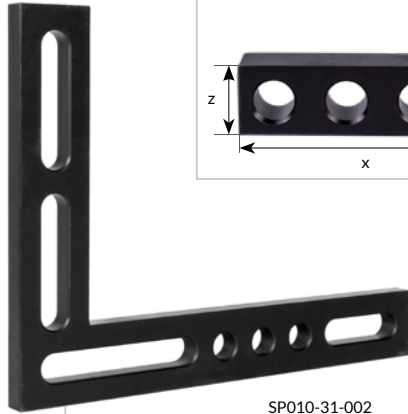

SP010-31-002
500mm × 375mm × 25mm



SP010-31-003
225mm × 275mm × 25mm



SP010-31-004
175mm × 175mm × 25mm



SP010-31-005
275mm × 175mm × 25mm

UNIVERSAL ADJUSTABLE ANGLE SQUARE WITH CLAMPING

used for clamping components at the correct angle.
Adjustment is possible from 0° to 225°.

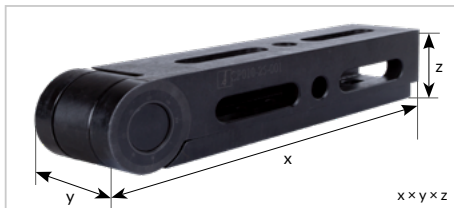

SP010-25-001

500mm x 100mm x 100mm

CORNER CONNECTOR

connects accessories and allows you to enhance the table's working space. Allows you to clamp and extend the construction in any plane.

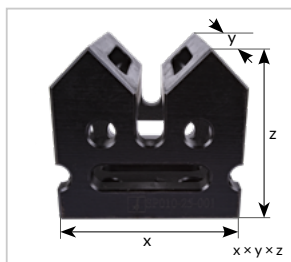

SP010-24-001

200mm x 200mm x 185mm

CLAMPING SLEEVES

are used for precise positioning of elements at the right angle. They are perfect for connecting working tubular structures.



SP010-64-001

gniazdo kątowe 45° \varnothing 28mm



SP010-64-002

gniazdo kątowe krótkie 45° \varnothing 28mm



SP010-64-003

gniazdo poziome \varnothing 28mm



SP010-64-004

gniazdo pionowe 90° \varnothing 28mm

PRISMS

are used to connect elements with round profiles and provide stable support for tubular structures.

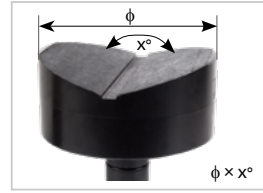

SP010-65-001A
 $\phi 60\text{mm} \times 90^\circ$



SP010-65-002A
 $\phi 60\text{mm} \times 120^\circ$



SP010-65-004
 $\phi 110\text{mm} \times 120^\circ$



SP010-65-006
 $\phi 60\text{mm} \times 150^\circ$



SP010-65-007
 $\phi 110\text{mm} \times 150^\circ$



SP010-65-008
 $\phi 140\text{mm} \times 150^\circ$

STOPS

make it easier to clamp constructions to the table as well as to perform precise and stable positioning of elements during welding.

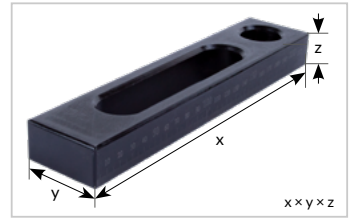

SP010-50-001
150mm × 50mm × 25mm



SP010-50-002
225mm × 50mm × 25mm



SP010-50-002A
225mm × 50mm × 25mm



SP010-50-014
500mm × 100mm × 25mm



SP010-50-006
1000mm × 100mm × 25mm



SP010-50-003
300mm × 50mm × 25mm

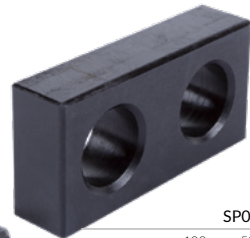

SP010-50-007
100mm × 50mm × 25mm

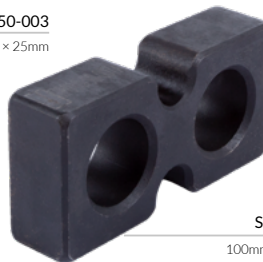

SP010-50-007A
100mm × 50mm × 25mm

| ACENTRIC TOGGLE LOCATING PLATE

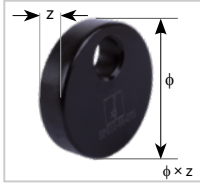

SP010-66-075
 $\phi 100\text{mm} \times 25\text{mm}$



| PLANE ANGLE LOCATOR



SP010-32-001
 $250\text{mm} \times 150\text{mm} \times 25\text{mm}$

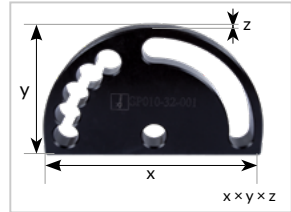

| CLAMPING BRIDGES

for clamping several workpieces of different sizes at two or three points at the same time, as well as for places with hard access.



SP010-63-001
 $185\text{mm} \times 30\text{mm} \times 13\text{mm}$

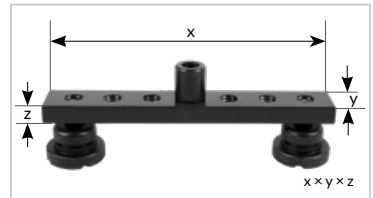

SP010-63-002
 $185\text{mm} \times 30\text{mm} \times 13\text{mm}$



CLAMPING BOLTS

are used to join accessories. They give an option of joining two or three elements, depending on their length.



SP010-60-001
28mm × 50mm



SP010-60-002
28mm × 75mm



SP010-60-003
28mm × 50mm

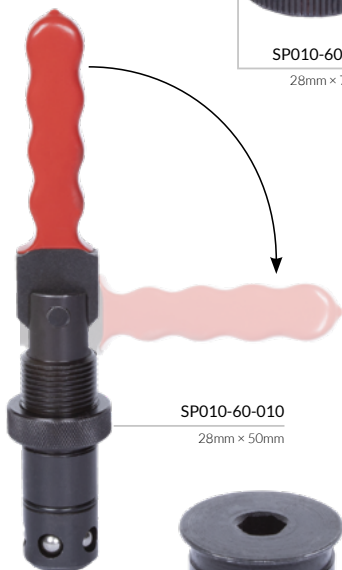

SP010-60-010
28mm × 50mm



SP010-60-102
28mm × 75mm



SP010-60-004
28mm × 75mm



SP010-60-101
28mm × 50mm



SP010-60-103
28mm × 50mm

TOGGLE CLAMPS

effectively lock and immobilize construction elements, at various angles, in the system openings.



SP010-70-001
300mm × 300mm



SP010-70-002
300mm × 150mm

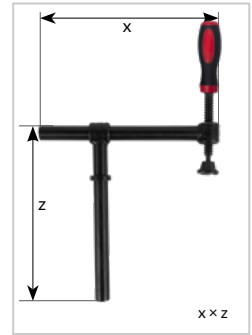

SP010-70-005
300mm × 200mm



SP010-70-004
300mm × 150mm



SP010-70-003
300mm × 300mm



SP010-70-014
300mm × 150mm



SP010-70-015
300mm × 200mm



SP010-70-024
300mm × 150mm



SP010-70-025
300mm × 200mm



SP010-70-011
300mm × 300mm



SP010-70-012
300mm × 150mm



SP010-70-013
300mm × 300mm



SP010-70-021
300mm × 300mm



SP010-70-023
300mm × 300mm

SP010-71-001

vertical with round block



SP010-71-002

push pull with round block

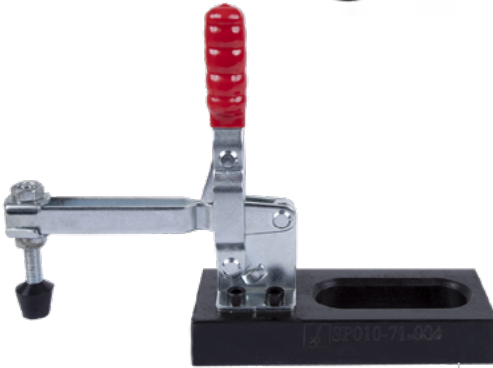

SP010-71-004

vertical with square block

SP010-71-003

horizontal with round block



SP010-71-006

horizontal with square block

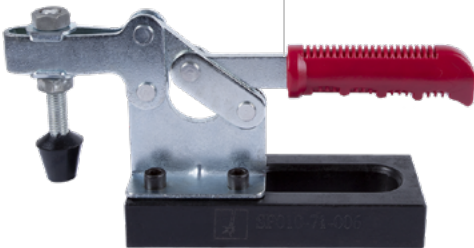

SP010-71-005

push pull with square block



MAINTENANCE

liquids and accessories will ensure that the tables are kept clean and, operate properly, which in turn will translate into effective and pleasant work.

SP010-90-001

oilstone 200 x 50 x 25mm (for cleaning)

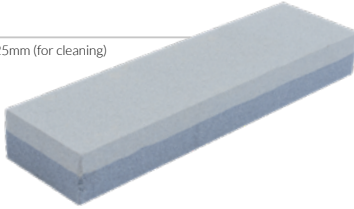

SP010-90-002

dispenser bottle 1L



SP010-90-004

nylon brush 30 x 80mm



SP010-90-005

welding tables cleaning 500ml



SP010-90-006

welding tables cleaning 5L



SP010-90-008

welding tables preservative 5L



SP010-90-007

welding tables preservative 500ml



ADDITIONAL ACCESSORIES

making work easier and faster as well as maintaining order and ergonomics at the workplace.

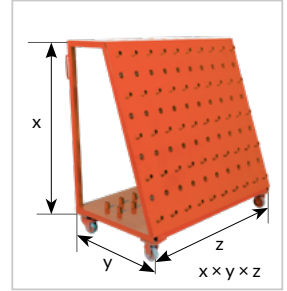

SP010-80-011

tool cart (without equipment)
1000 × 600 × 1065mm

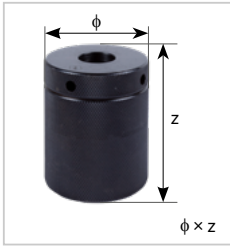

SP010-67-001
adjustable spacer 80 × 100mm

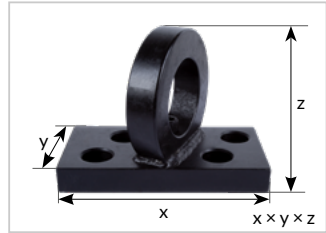

SP010-80-002
shipping bracket with fastening plate 185 × 100 × 135mm



SP010-80-003
ground connector



SP010-68-001
spacer set 0.5 × 20mm (11 pieces)



SP010-90-003A
hexagon allen wrench 150mm



KITS

KIT 01

SP010-99-SET01

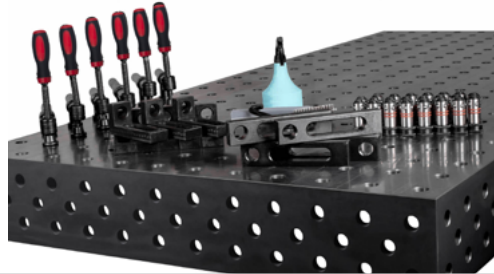

SP010-30-005	Angle 175x50x75mm hole/slot	8 pcs
SP010-50-002	Universal stop 225x50x25mm	4 pcs
SP010-70-001	Compensating clamp 180° with handle 300x300mm	6 pcs
SP010-60-001	Rapid locking bolt fi 28x50mm	22 pcs
SP010-90-003A	Hexagon allen wrench 150mm	1 pc
SP010-90-004	Nylon brush 30x80mm	1 pc
SP010-90-001	Oilstone for cleaning 200x50x25mm	1 pc
SP010-90-002	Spray bottle	1 pc

KIT 02

SP010-99-SET02



SP010-30-002	Angle 175x50x175mm hole/slot	6 pcs
SP010-30-005	Angle 175x50x75mm hole/slot	2 pcs
SP010-50-002	Universal stop 225x50x25mm	4 pcs
SP010-70-001	Compensating clamp 180° with handle 300x300mm	8 pcs
SP010-60-001	Rapid locking bolt fi 28x50mm	20 pcs
SP010-90-003A	Hexagon allen wrench 150mm	1 pc
SP010-90-004	Nylon brush 30x80mm	1 pc
SP010-90-001	Oilstone for cleaning 200x50x25mm	1 pc
SP010-90-002	Spray bottle	1 pc

KITS

We also offer ready-made kits, in various configurations, tailored to the production needs of each client.

KIT 01A

SP010-99-SET01A

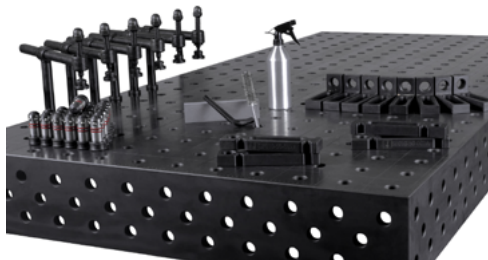

SP010-30-005	Clamping and locating angle bores 175x50x75mm hole/slot	8 pcs
SP010-50-002A	Universal-stop 225x50x25mm	4 pcs
SP010-60-001	Rapid locking bolt fi28x50mm	22 pcs
SP010-70-021	Screw type clamping with outer hexagon bolt head 300x300 180°	6 pcs
SP010-90-001	Oilstone for cleaning 200x50x25mm	1 pcs
SP130-01-102	Spray bottle	1 pc
SP010-90-003A	Hexagon allen wrench 150mm	1 pc
SP010-90-004	Nylon brush 30x80mm	1 pc

KIT 02A

SP010-99-SET02A

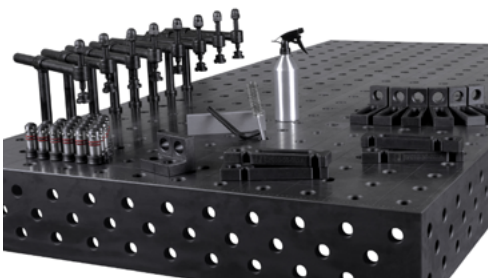

SP010-30-005	Clamping and locating angle bores 175x50x75mm hole/slot	6 pcs
SP010-30-006	Clamping and locating angle bores 75x50x75mm	2 pcs
SP010-50-002A	Universal-stop 225x50x25mm	4 pcs
SP010-60-001	Rapid locking bolt fi28x50mm	20 pcs
SP010-70-021	Screw type clamping with outer hexagon bolt head 300x300mm 180°	8 pcs
SP010-90-001	Oilstone for cleaning 200x50x25mm	1 pc
SP130-01-102	Spray bottle	1 pc
SP010-90-003A	Hexagon allen wrench 150mm	1 pc
SP010-90-004	Nylon brush 30x80mm	1 pc

KIT 03

SP010-99-SET03

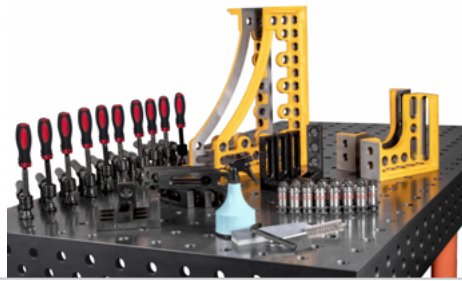

SP010-23-300L	Angle 275x100x300mm left	1 pc
SP010-23-300R	Angle 275x100x300mm right	1 pc
SP010-23-600L	Angle 375x100x600mm left	1 pc
SP010-23-600R	Angle 375x100x600mm right	1 pc
SP010-30-002	Angle 175x50x175mm hole/slot	4 pcs
SP010-30-005	Angle 175x50x75mm hole/slot	4 pcs
SP010-50-002	Universal stop 225x50x25mm	6 pcs
SP010-70-001	Compensating clamp 180° with handle 300x300mm	10 pcs
SP010-60-001	Rapid locking bolt fi 28x50mm	22 pcs
SP010-90-003A	Hexagon allen wrench 150mm	1 pc
SP010-90-004	Nylon brush 30x80mm	1 pc
SP010-90-001	Oilstone for cleaning 200x50x25mm	1 pc
SP010-90-002	Spray bottle	1 pc

KIT 04

SP010-99-SET04

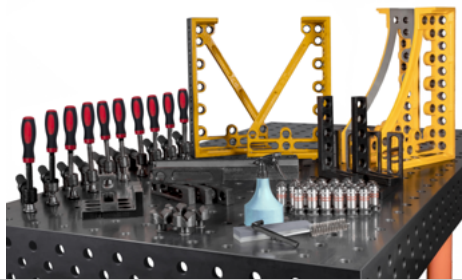

SP010-23-600L	Angle 375x100x600mm left	2 pcs
SP010-23-600R	Angle 375x100x600mm right	2 pcs
SP010-30-005	Angle 175x50x75mm hole/slot	4 pcs
SP010-30-013	Angle 175x50x275mm hole/slot	6 pcs
SP010-50-002	Universal stop 225x50x25mm hole/slot	4 pcs
SP010-65-001A	V-block locations fi 60mm 90°	4 pcs
SP010-70-001	Compensating clamp 180° with handle 300x300mm	10 pcs
SP010-60-001	Rapid locking bolt fi 28x50mm	28 pcs
SP010-90-003A	Hexagon allen wrench 150mm	1 pc
SP010-90-004	Nylon brush 30x80mm	1 pc
SP010-90-001	Oilstone for cleaning 200x50x25mm	1 pc
SP010-90-002	Spray bottle	1 pc

KIT 03A

SP010-99-SET03A



SP010-23-600L	Clamping and locating angle 375x100x600mm (left)	1 pc
SP010-23-600R	Clamping and locating angle 375x100x600mm (right)	1 pc
SP010-31-004	Flat angle bracket 175x175x25mm	4 pcs
SP010-30-005	Clamping and locating angle bores 175x50x75mm hole/slot	4 pcs
SP010-50-002A	Universal-stop 225x50x25mm	6 pcs
SP010-60-001	Rapid locking bolt fi28x50mm	22 pcs
SP010-70-011	Screw type clamping with swivel handle 300x300mm 180°	6 pcs
SP010-70-012	90° screw type clamping with swivel handle 300x150mm	2 pcs
SP010-70-013	Screw type clamping with swivel handle 300x300mm 45°	2 pcs
SP010-90-001	Oilstone for cleaning 200x50x25mm	1 pc
SP130-01-102	Spray bottle	1 pc
SP010-90-003A	Hexagon allen wrench 150mm	1 pc
SP010-90-004	Nylon brush 30x80mm	1 pc

KIT 04A

SP010-99-SET04A



SP010-23-600L	Clamping and locating angle 375x100x600mm (left)	1 pc
SP010-23-600R	Clamping and locating angle 375x100x600mm (right)	1 pc
SP010-22-030	Spacer angle U-shape 300x200x100mm	1 pc
SP010-30-005	Clamping and locating angle bores 175x50x75mm hole/slot	4 pcs
SP010-31-004	Flat angle bracket 175x175x25mm	2 pcs
SP010-50-002A	Universal-stop 225x50x25mm	4 pcs
SP010-60-002	Rapid locking bolt fi28x75mm	10 pcs
SP010-60-001	Rapid locking bolt fi28x50mm	28 pcs
SP010-65-002A	V-block Locations fi60mm 120°	4 pcs
SP010-70-011	Screw type clamping with swivel handle 300x300mm 180°	6 pcs
SP010-70-012	90° screw type clamping with swivel handle 300x150mm	2 pcs
SP010-70-013	Screw type clamping with swivel handle 300x300mm 45°	2 pcs
SP010-90-001	Oilstone for cleaning 200x50x25mm	1 pc
SP130-01-102	Spray bottle	1 pc
SP010-90-003A	Hexagon allen wrench 150mm	1 pc
SP010-90-004	Nylon brush 30x80mm	1 pc

KIT 05

SP010-99-SET05

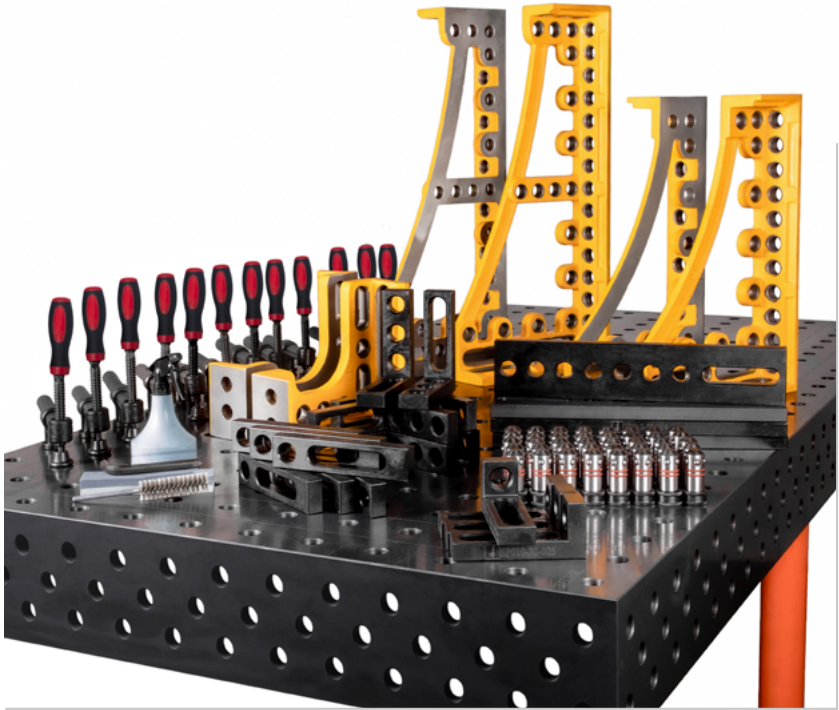

SP010-23-300L	Angle 275x100x300mm left	1 pc
SP010-23-300R	Angle 275x100x300mm right	1 pc
SP010-23-600L	Angle 375x100x600mm left	1 pc
SP010-23-600R	Angle 375x100x600mm right	1 pc
SP010-23-800L	Angle 375x100x800mm left	1 pc
SP010-23-800R	Angle 375x100x800mm right	1 pc
SP010-30-002	Angle 175x50x175mm hole/slot	6 pcs
SP010-30-005	Angle 175x50x75mm hole/slot	4 pcs
SP010-50-002	Universal stop 225x50x25mm hole/slot	6 pcs
SP010-50-014	Universal stop 500x100x25mm hole/slot	4 pcs
SP010-70-001	Compensating clamp 180° with handle 300x300mm	12 pcs
SP010-60-001	Rapid locking bolt fi 28x50mm	40 pcs
SP010-90-003A	Hexagon allen wrench 150mm	1 pc
SP010-90-004	Nylon brush 30x80mm	1 pc
SP010-90-001	Oilstone for cleaning 200x50x25mm	1 pc
SP010-90-002	Spray bottle	1 pc

KIT 05A

SP010-99-SET05A

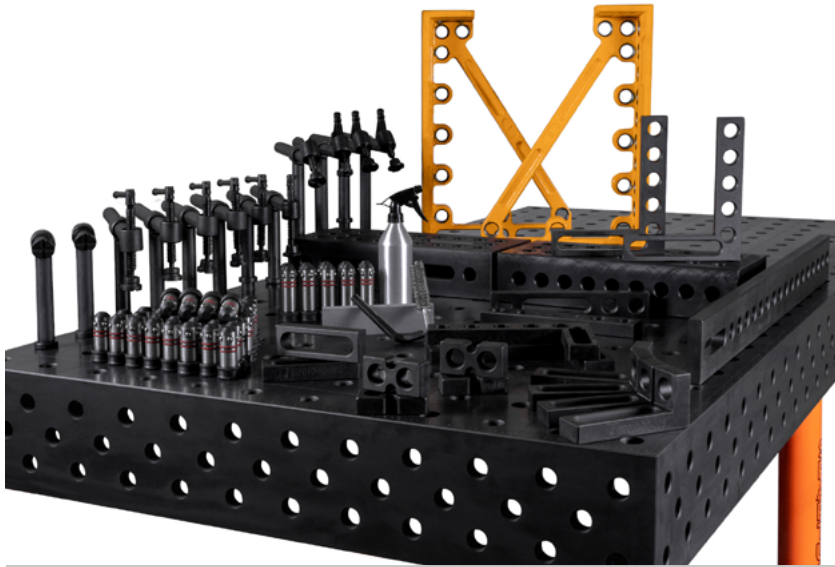

SP010-23-600L	Clamping and locating angle 375x100x600mm (left)	1 pc
SP010-23-600R	Clamping and locating angle 375x100x600mm (right)	1 pc
SP010-22-050	Spacer angle U-shape 500x200x100mm	2 pcs
SP010-31-003	Flat angle bracket 225x275x25mm	2 pcs
SP010-31-005	Flat angle bracket 275x175x25mm	2 pcs
SP010-30-005	Clamping and locating angle bores 175x50x75mm hole/slot	4 pcs
SP010-50-003	Universal-stop 300x50x25mm	2 pcs
SP010-50-001	Universal-stop 150x50x25mm	2 pcs
SP010-50-006	Universal-stop 1000x100x25mm	1 pc
SP010-50-007A	Universal-stop 100x50x25mm	4 pcs
SP010-60-001	Rapid locking bolt f128x50mm	40 pcs
SP010-60-002	Rapid locking bolt f128x75mm	10 pcs
SP010-70-013	Screw type clamping with swivel handle 300x300mm 45°	4 pcs
SP010-70-012	90° screw type clamping with swivel handle 300x150mm	2 pcs
SP010-70-011	Screw type clamping with swivel handle 300x300mm 180°	6 pcs
SP010-90-001	Oilstone for cleaning 200x50x25mm	1 pc
SP130-01-102	Spray bottle	1 pc
SP010-90-003A	Hexagon allen wrench 150mm	1 pc
SP010-90-004	Nylon brush 30x80mm	1 pc

KIT 06

SP010-99-SET06



SP010-20-050	Spacer angle U-shape 500x200x200mm	2 pcs
SP010-20-100	Spacer angle U-shape 1000x200x200mm	2 pcs
SP010-23-300L	Angle 275x100x300mm left	2 pcs
SP010-23-300R	Angle 275x100x300mm right	2 pcs
SP010-23-600L	Angle 375x100x600mm left	2 pcs
SP010-23-600R	Angle 375x100x600mm right	2 pcs
SP010-30-002	Angle 175x50x175mm hole/slot	8 pcs
SP010-30-005	Angle 175x50x75mm hole/slot	8 pcs
SP010-30-013	Angle 175x50x275mm hole/slot	4 pcs
SP010-50-002	Universal stop 225x50x25mm hole/slot	8 pcs
SP010-50-014	Universal stop 500x100x25mm hole/slot	4 pcs
SP010-70-001	Compensating clamp 180° with handle 300x300mm	20 pcs
SP010-60-001	Rapid locking bolt fi 28x50mm	46 pcs
SP010-90-003A	Hexagon allen wrench 150mm	1 pc
SP010-90-004	Nylon brush 30x80mm	1 pc
SP010-90-001	Oilstone for cleaning 200x50x25mm	1 pc
SP010-90-002	Spray bottle	1 pc

KIT 06A

SP010-99-SET06A

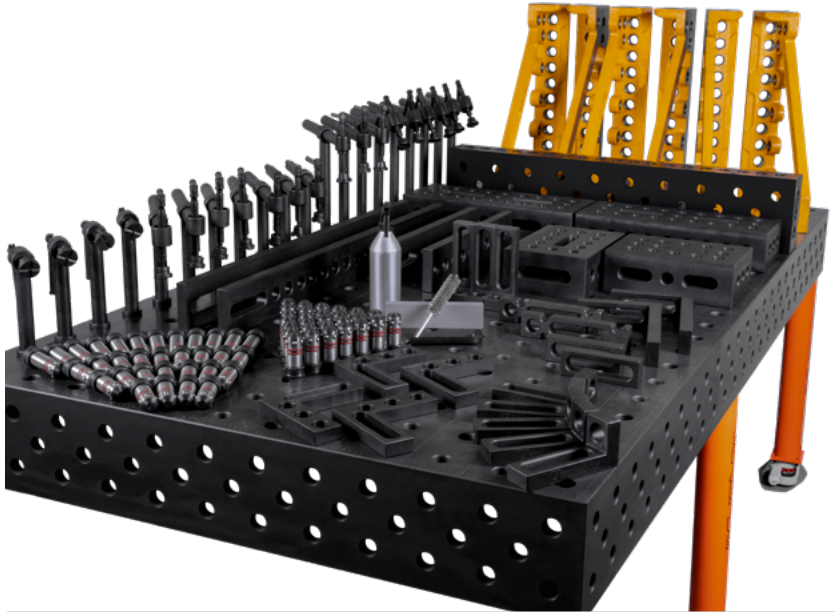

SP010-22-050	Spacer angle U-shape 500x200x100mm	2 pcs
SP010-22-030	Spacer angle U-shape 300x200x100mm	2pcs
SP010-23-600L	Clamping and locating angle 375x100x600mm (left)	3 pcs
SP010-23-600R	Clamping and locating angle 375x100x600mm (right)	3 pcs
SP010-21-100	Spacer angle L-shape 1000x200x100mm	1 pc
SP010-30-005	Clamping and locating angle bores 175x50x75mm hole/slot	8 pcs
SP010-31-004	Flat angle bracket 175x175x25mm	4 pcs
SP010-30-003	Clamping and locating angle bores 175x50x175mm slot/slot	2 pcs
SP010-50-001	Universal-stop 150x50x25mm	2 pcs
SP010-50-002A	Universal-stop 225x50x25mm	2 pcs
SP010-50-014	Universal-stop 500x100x25mm holes/slot	2 pcs
SP010-50-006	Universal-stop 1000x100x25mm	2 pcs
SP010-60-001	Rapid locking bolt fi 28x50mm	48 pcs
SP010-60-002	Rapid locking bolt fi 28x75mm	12 pcs
SP010-70-013	Screw type clamping with swivel handle 300x300mm 45°	6 pcs
SP010-70-012	90° screw type clamping with swivel handle 300x150mm	4 pcs
SP010-70-011	Screw type clamping with swivel handle 300x300mm 180°	10 pcs
SP010-90-001	Oilstone for cleaning 200x50x25mm	1 pc
SP130-01-102	Spray bottle	1 pc
SP010-90-003A	Hexagon allen wrench 150mm	1 pc
SP010-90-004	Nylon brush 30x80mm	1 pc

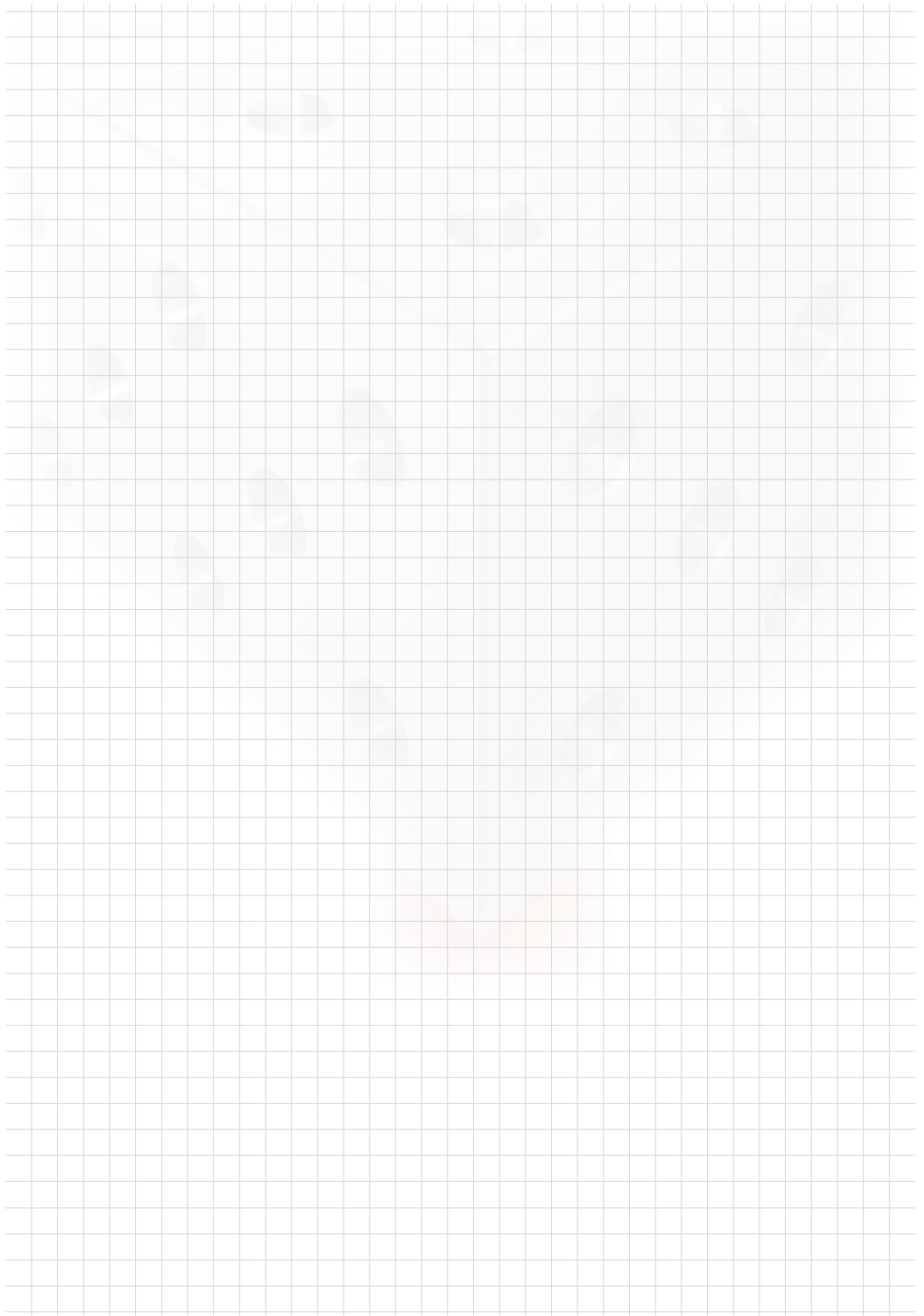

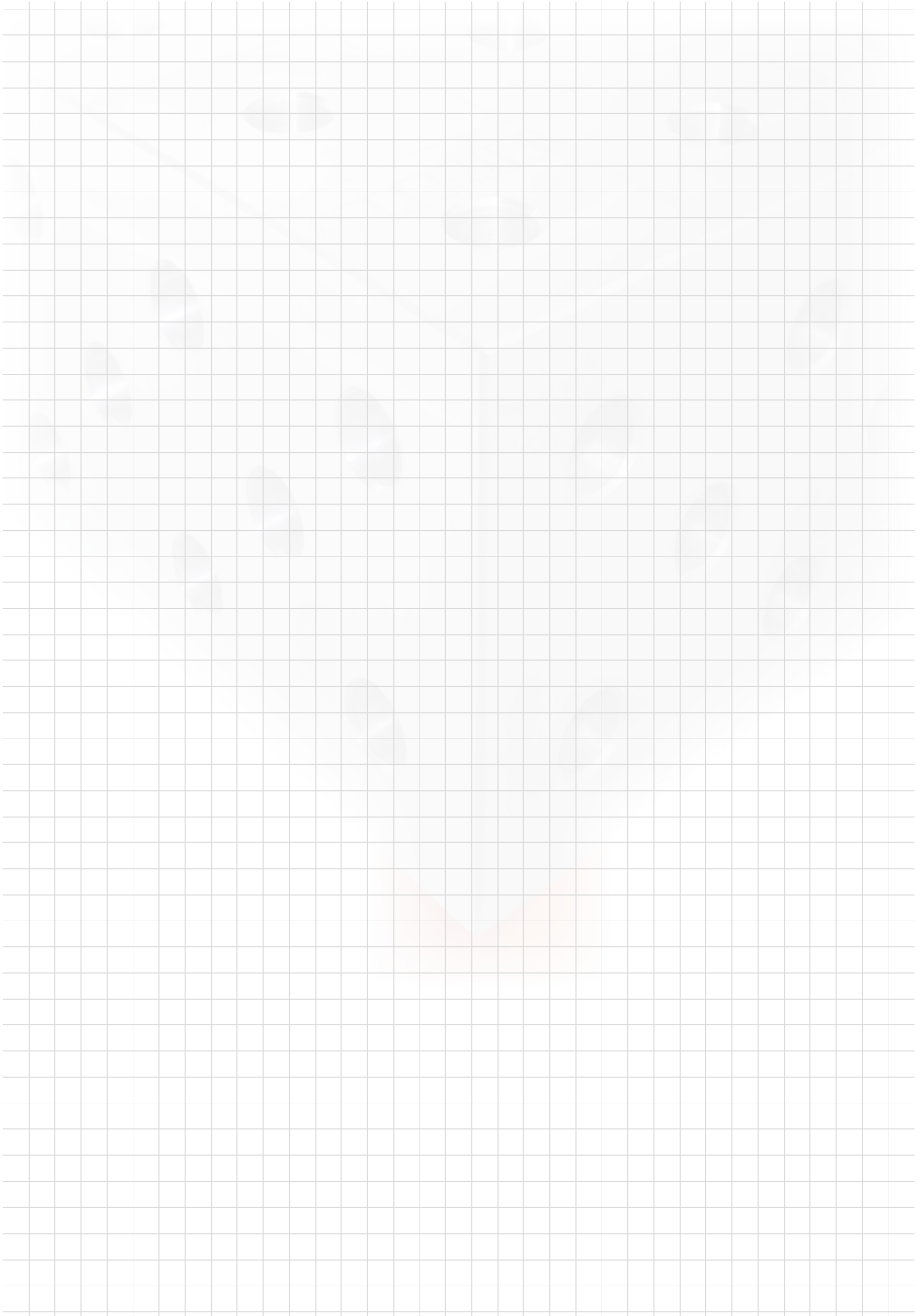

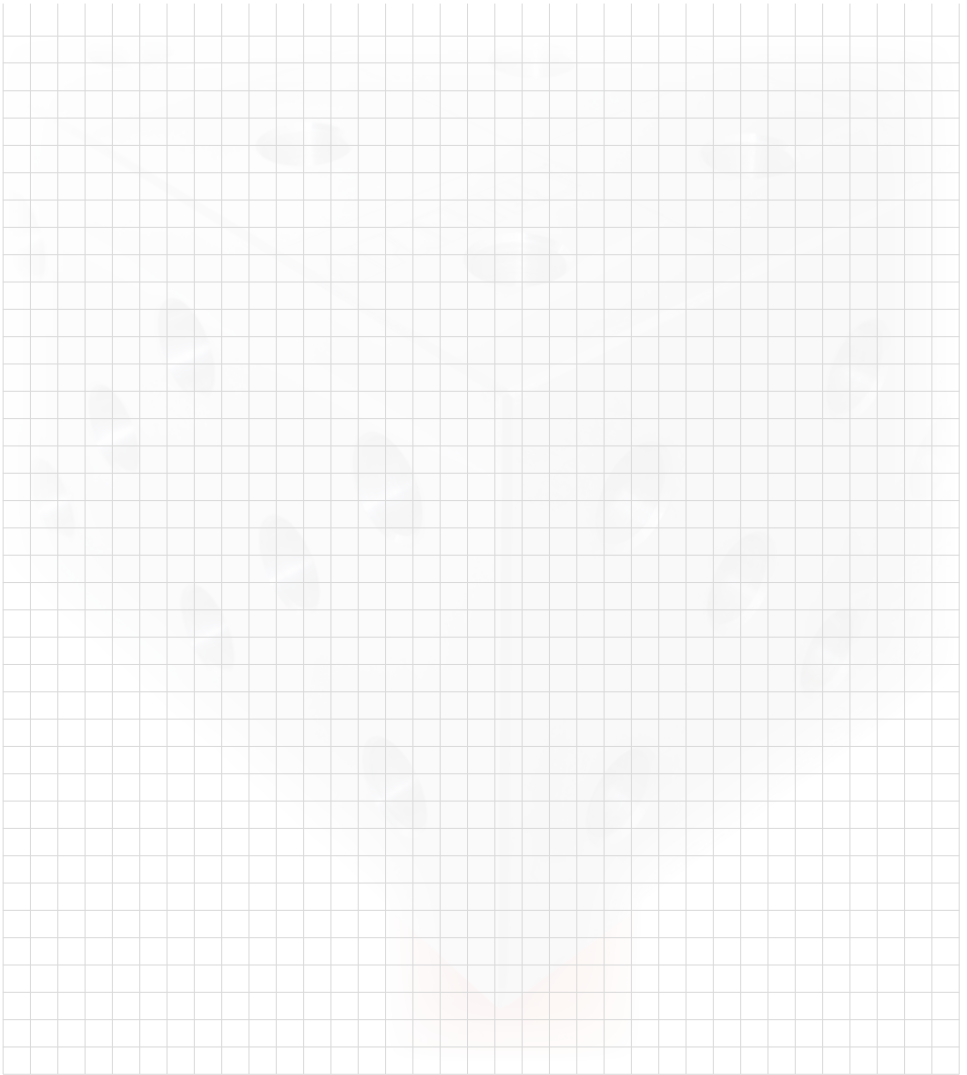

ASSORTMENT TO PURCHASE:

